

# MINERALÖLABSCHEIDER KLASSE II SEPARATORE OLI MINERALI CLASSE II

## ÖKOSTAR 3lt./sec.

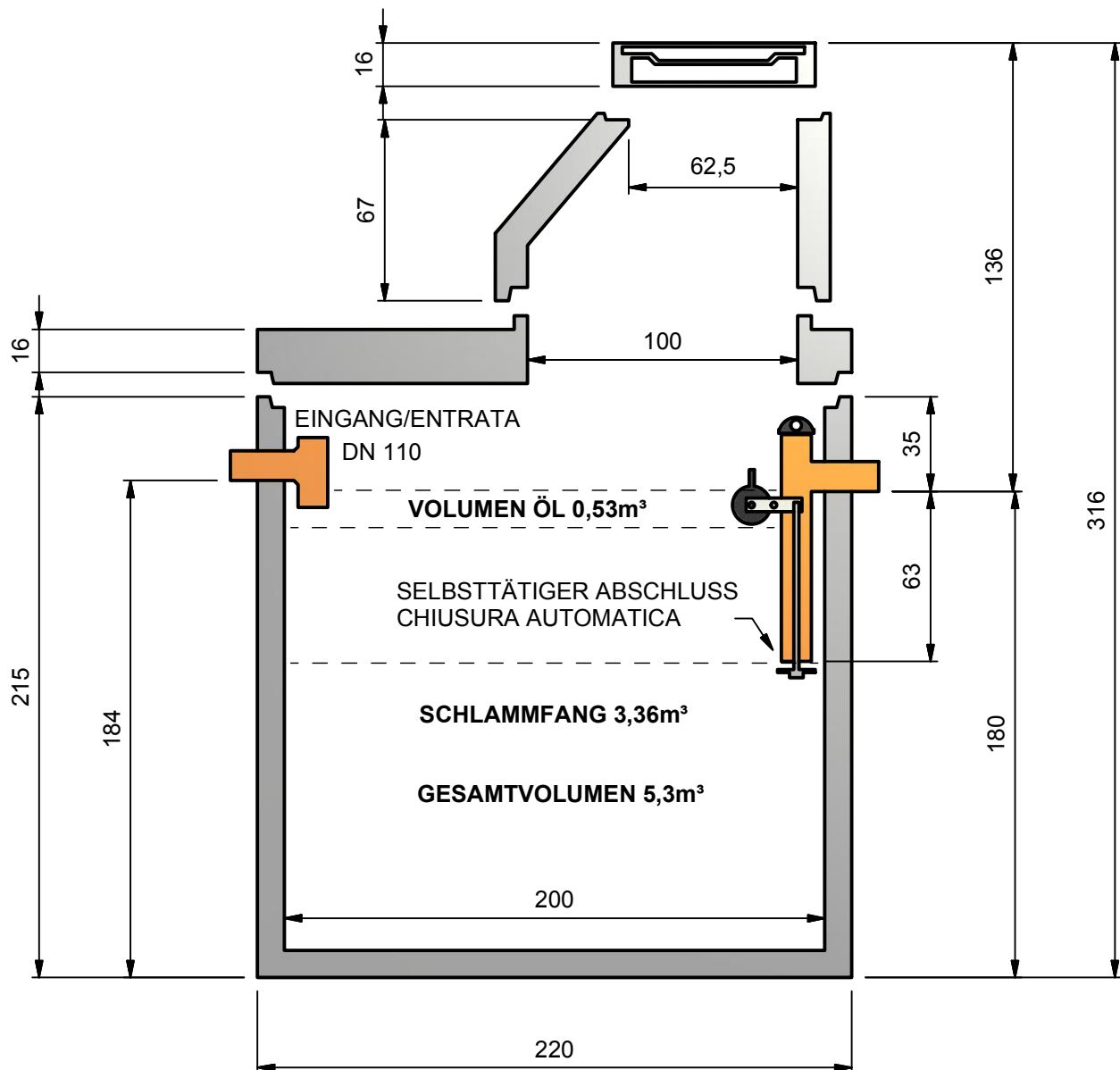

<b>Gewichte - pesi</b>			
Wanne - vasca	4000 kg	Ausgleichsring - anello raggiungiquota	kg
Abdeckplatte - piastra copertura	1300 kg	Deckel - coperchio 125KN	100 kg
Konus - riduzione	625 kg	Deckel - coperchio 400KN	190 kg
Norm EN 858 - 1 : 2002, EN 858 - 2 : 2003, DIN 1999 - 100 : 2003			

# MINERALÖLABSCHEIDER KLASSE II SEPARATORE OLI MINERALI CLASSE II

## ÖKOSTAR 6lt./sec.

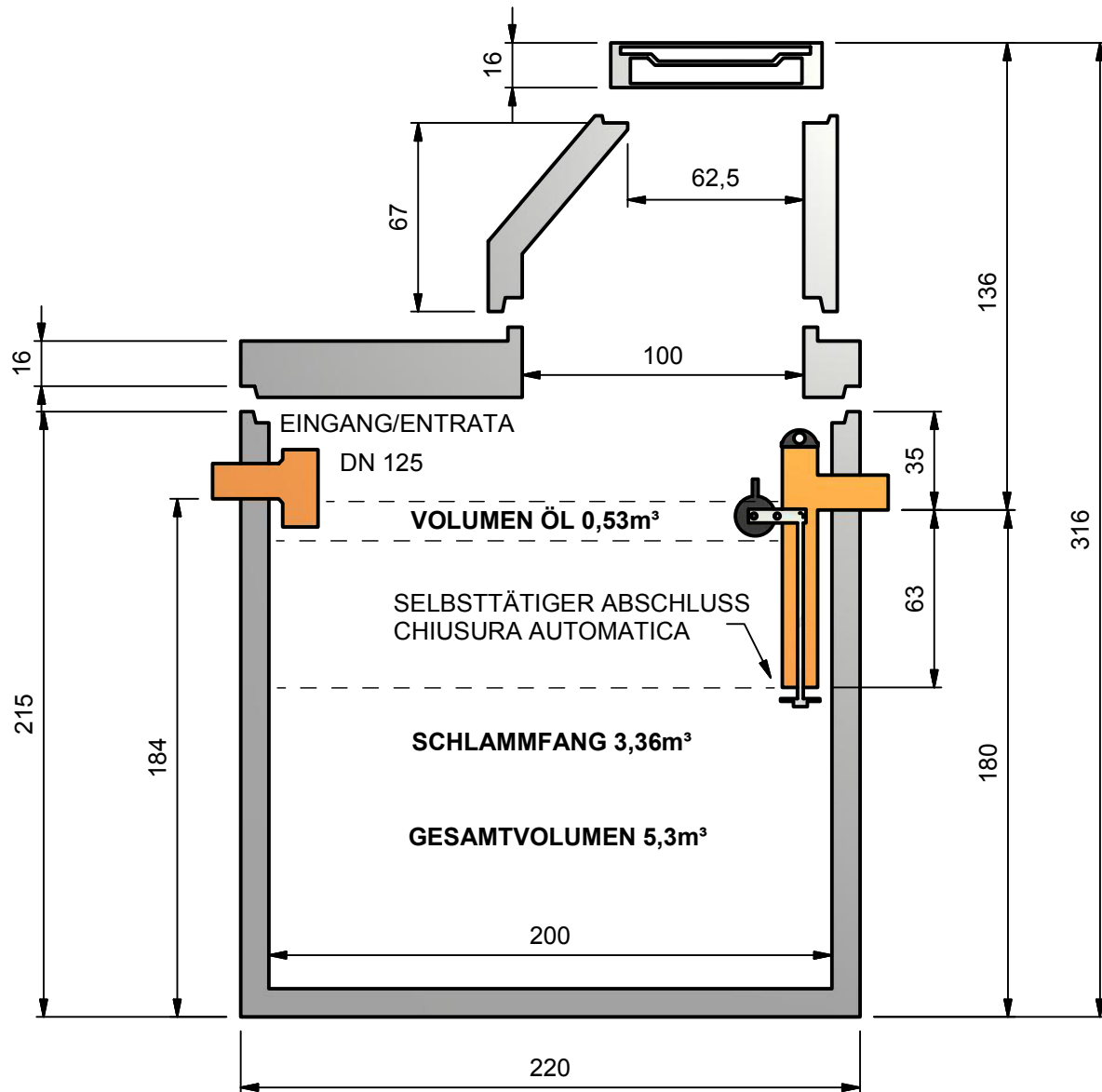

<b>Gewichte - pesi</b>			
Wanne - vasca	4000 kg	Ausgleichsring - anello raggiungiquota	0 kg
Abdeckplatte - piastra copertura	1300 kg	Deckel - coperchio 125KN	100 kg
Konus - riduzione	625 kg	Deckel - coperchio 400KN	190 kg
Norm EN 858 - 1 : 2002, EN 858 - 2 : 2003, DIN 1999 - 100 : 2003			

**NEOLIT**

betonmanufaktur. manifattura calcestruzzo



# MINERALÖLABSCHEIDER KLASSE II SEPARATORE OLI MINERALI CLASSE II

## ÖKOSTAR 10lt./sec.

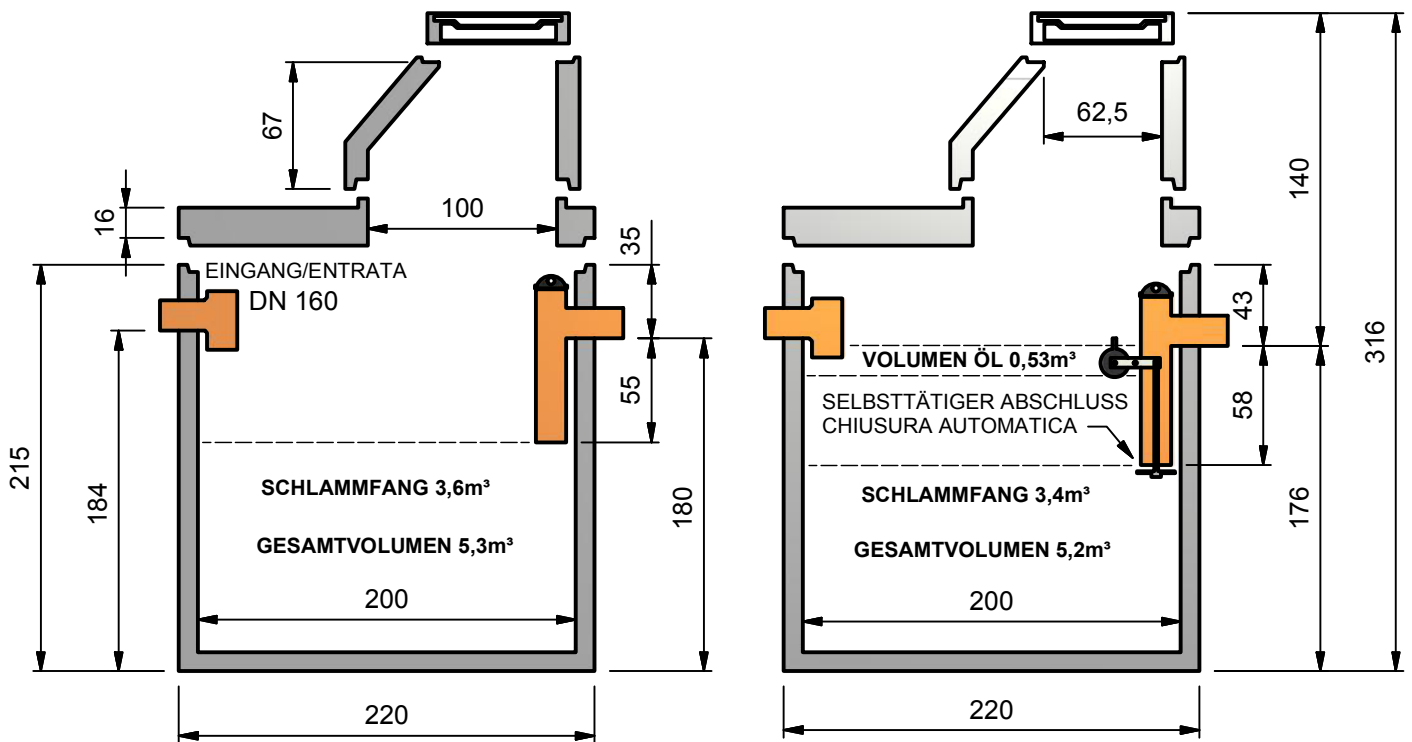

### Gewichte - pesi

Wanne - vasca	2x	4000 kg	Ausgleichsring - anello raggiungiquota	kg
Abdeckplatte - piastra copertura	2x	1300 kg	Deckel - coperchio 125KN	2x 100 kg
Konus - riduzione	2x	625 kg	Deckel - coperchio 400KN	2x 190 kg
Norm EN 858 - 1 : 2002, EN 858 - 2 : 2003, DIN 1999 - 100 : 2003				



# MINERALÖLABSCHEIDER KLASSE II SEPARATORE OLI MINERALI CLASSE II

## ÖKOSTAR 20lt./sec.

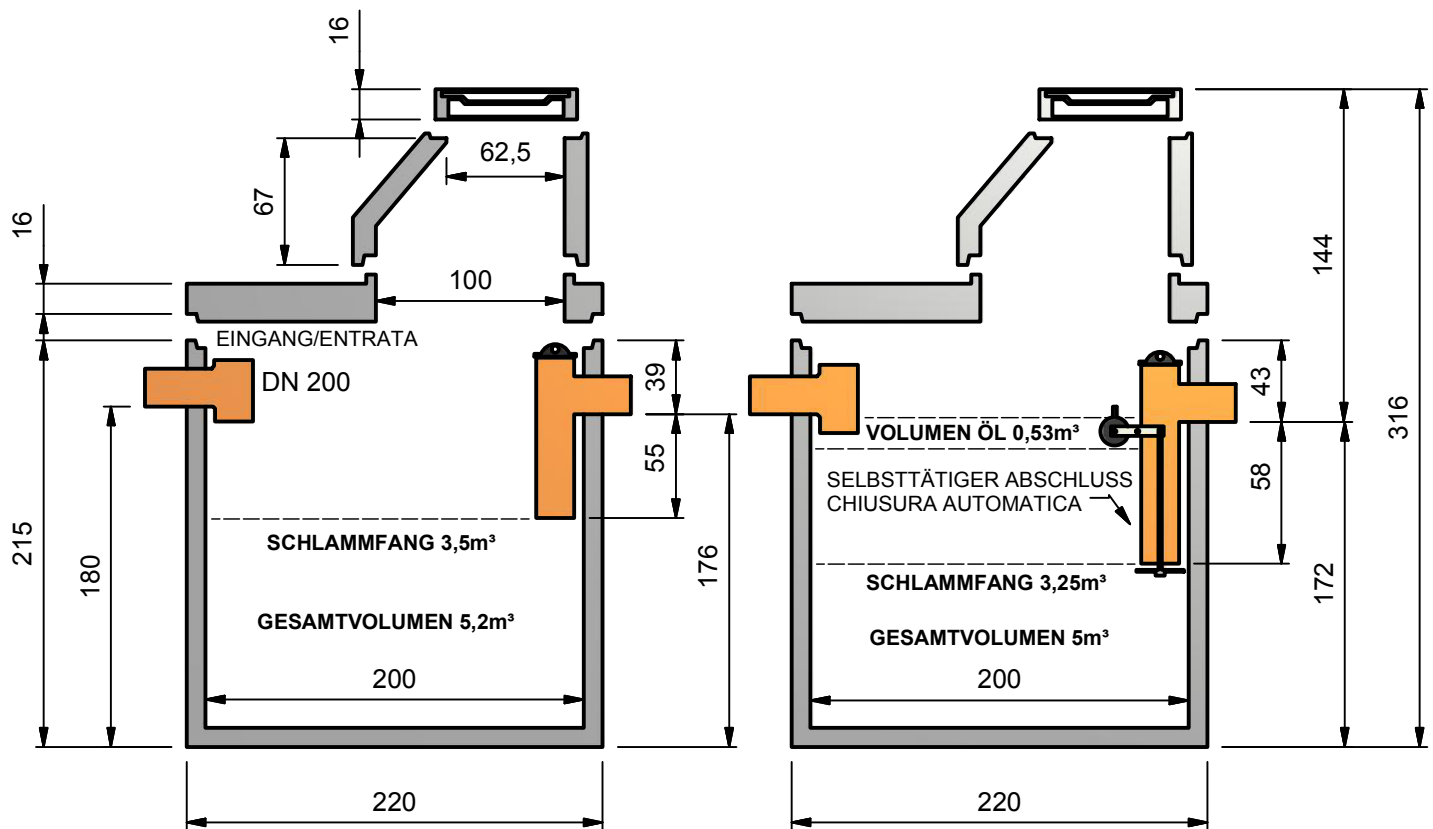

### Gewichte - pesi

Wanne - vasca	2 x	4000 kg	Ausgleichsring - anello raggiungiquota	kg
Abdeckplatte - piastra copertura	2 x	1300 kg	Deckel - coperchio 125KN	2 x 100 kg
Konus - riduzione	2 x	625 kg	Deckel - coperchio 400KN	2 x 190 kg
Norm EN 858 - 1 : 2002, EN 858 - 2 : 2003, DIN 1999 - 100 : 2003				